

# ALTOm

## ARO-15

Reverse osmosis 15 gpm

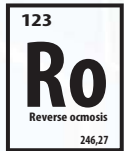

Daily production chart  
(liters/minute)

TDS (NaCl) inlet water (mg/l)

°C/°F	500	1 000	2 000
25/77	(gpm) 15,0	14,5	13,5
	(lpm) 56,8	54,9	51,1
15/59	(gpm) 15,0	15,0	11,8
	(lpm) 56,8	56,8	44,7
5/41	(gpm) 11,3	10,2	8,0
	(lpm) 42,8	38,6	30,3

\* Inlet water parameters used for calculations: raw water at 25°C. SDI < 3, no counterpressure.

### Components

Inlet valve	2" Electric valve
Prefilter	5 microns filter bag
Pressurization pump	Multistage 304 stainless steel
Motor	5HP TEFC
Low pressure protection	Pressure switch
Membrane housing	FRP
Membrane type	TFC - Low energy
Membrane dimensions	102 x 1 016 mm (4 x 40")
Number of membranes	12
Membrane surface m <sup>2</sup> (pi <sup>2</sup> )	97,2 (1044)
Matrix configuration	2/4 Recovery
Internal recirculation loop	1,5" PVC
Recirculation control	3/4" PVC Globe Valve
Drain control	3/4" PVC Globe Valve
Recirculation flowmeter	0-151,4 lpm (0-40 gpm)
Drain flowmeter	0-151,4 lpm (0-40 gpm)
Permeate flowmeter	0-151,4 lpm (0-40 gpm)
System shutoff control	Float/contact device
Inlet water quality monitor	0-1 000 µS
Permeate water quality control	0-250 µS
Display screen	Printed circuit board, 2 line screen

### Connections

Electric power supply	208-240VAC/1ph/60Hz/50Hz
	208-575/3ph/60Hz
	380VAC/3ph/50Hz
	Other power supply configurations available on demand
Inlet	2" PVC Union
Permeate	1,5" PVC Union
Reject	1,5" PVC Union
PüreRince process	3/4" PVC Union
Cleaning station inlet	2" PVC Union
Cleaning station outlet	1,5" PVC Union (2 connections)

### Feed water

Inlet pressure	30-50 psi (2,1 - 3,4 bar)
Temperature	4 - 30°C
pH	2 - 11 SU
Chlorine (Max.)	0,05 mg/l
Hardness (Max.)	103 mg/l (6 gpg)
Iron (Max.)	0,3 mg/l
Silica (Max.)	10,0 mg/l
Total dissolved solids (Max.)	3 000 mg/l

### Operating specs

Inlet flow rate @ 65 %	87,3 lpm (23,1 gpm)
Permeate flow rate*	56,8 lpm (15,0 gpm)
Reject flow rate @ 65%	30,6 lpm (8,1 gpm)
Daily production	81 750 l (21 600 gal)
Operating pressure	100-150 psi (6,9 - 10,3 bar)
Max. pressure - shutdown	175 psi (12,1 bar)
Min. pressure - shutdown	15 psi (1,0 bar)
Rejection percentage	97 % - 99 %
Typical recovery ratio	50 % - 75 %
PüreRince time	10 minutes
PüreRince volume	189,3 l (50 gal)
Width x Depth x Height	2 743 x 914 x 1 626 mm (108" x 36" x 64")
Weight	480 kg (1060 lbs)

### Options

Raw water conductivity probe
Reject water conductivity probe
BACnet or Modbus communication protocols available
Direct feed
Programmable logic controllers (PLC)
Stainless steel piping (316)
Alternate or auxiliary pump
Upgrade for brackish water
Stainless steel skid

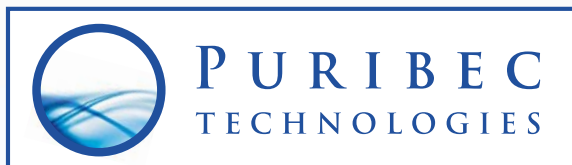

# Reverse osmosis 15 gpm

## Technical specifications : Commercial and industrial reverse osmosis systems

### Operating profile

The system uses reverse osmosis technology to remove micropollutants, to improve color and reduce total dissolved solids (TDS) level in water by a minimum of 95%, depending on raw water quality. System contains its own pressurization system to optimize the production of water through the membranes. System operating pressure should be between 100 and 150 (6,9 and 10,3 bar). System functionalities include monitoring and regulating devices to adjust the system's operating pressure. The system contains an automatic inlet valve that closes when a tank full or a problem signal is received. A low pressure switch serves to protect pump from cavitation damage during low pressure occurrences. On/Off cycling is based on a parametrable normally open or closed dry contact.

### Pump design

Units use a multi-stage centrifuge pump. Wet end is 304 stainless steel (also available in 316 stainless steel). Pump motor is NEMA rated and designed with fully partitioned cooling fan and is tri-phase powered (also available in single phase) . The pump uses multiple turbine stages to increase the water pressure between 100 and 150 (6,9 and 10,3 bar).

### Membranes and housings

System uses 12 TFC low energy membranes, each one being 102 x 1 016mm (4.0" x 40") in size, to treat up to 15 gallons of water per minute, based on a 25°C operating temperature. The membrane device is designed for a low energy operation, at a pressure below 150 psi (10.3 bar). Membrane housings are made of fiber glass and rated for operation at pressures up to 250 psi (17.2 bar). Six membrane housings are included in the system and each one contains two membranes. The system includes a rejection recovery device adjustable with manual valves.

### Plumbing configuration

The system is calibrated for maximum operating pressure of 150 psi (10.3 bar) . Primary plumbing components are PVC 80. The system provides an internal adjustment of the recirculated and rejection flow. Rejection recirculation data is displayed on the operator interface panel at the front. The feed and pump pressures are also shown. Recirculation valves are placed for easy access and permeate sampling ports are located on each membrane housing.

### System controls

All system controls are automated and controlled by an integrated circuit. The system continuously displays produced water quality data in microSiemens ( $\mu\text{s}$ ). The controller activates the alarm system , including high or low pressure and low quality of raw and treated water. During the shutdown, the feed side of the membrane is flushed with treated water. All electronic components are enclosed in a sealed non-metallic NEMA 4X housing . System controls include a main switch that can interrupt the main power supply.

### Skid

System dimensions do not exceed 2743 x 914 x 1626 mm (108 x 36 x 64 "). The system is assembled on a steel structure covered with epoxy paint. Also available in stainless steel upon request.

# ALtUm

## ARO-15

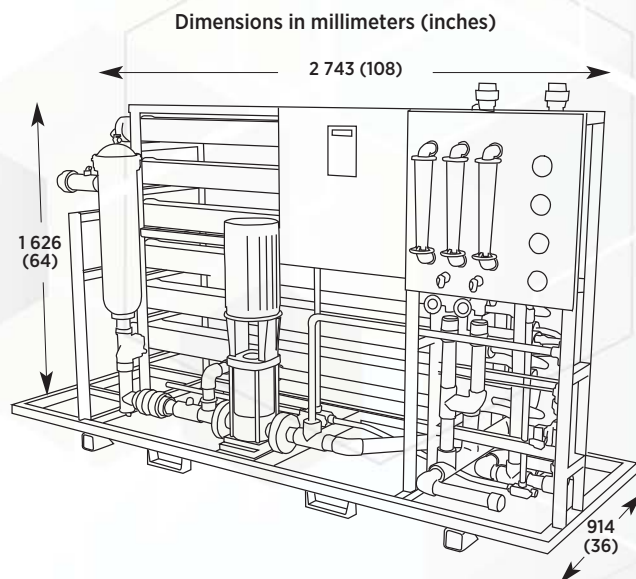

### Distributed by



### Made by



546, chemin Olivier, Levis (Quebec) G7A 1P1

Phone: 418.839.8115 / 1.800.839.8115

Fax: 418.831.7511

[www.puribectechnologies.com/](http://www.puribectechnologies.com/) [information@puribec.com](mailto:information@puribec.com)